



LIMITED WARRANTY

All COBB CUSTOM wood products are warranted for the time period set forth below, subject to the restrictions, limitations, exclusions and conditions which follow, to be free of defects which would render said wood products unserviceable or unfit for ordinary, recommended use.

The limited warranty period shall be one (1) year from invoice date for COBB CUSTOM wood products – unfinished and prehung.

If a COBB CUSTOM wood product does not meet the above stated standards, COBB CUSTOM will, at its discretion either repair the product, replace the product in the original condition supplied to the distributor, or refund the original purchase price paid to COBB CUSTOM for the product.

Unless otherwise expressly provided herein, COBB CUSTOM shall not pay for the cost of labor, installation or finishing of the replacement or original product or for any cost relating to the replacement of the product, all of which shall be the sole responsibility of the person making the warranty claim. All visible defects must be reported in the manner as described before product or products are originally installed.

COBB CUSTOM insulated glass units will be warranted against seal failure only if installed in the unit by COBB CUSTOM and will be replaced free of charge for one (1) year.

This warranty does **not** cover breakage of glass from any cause whatsoever.

Claims under this Limited Warranty must be made in writing within the period of this warranty and prior to the beginning of any repair work to: Warranty Services, COBB CUSTOM, 1905 Riverview Drive, San Bernardino, California 92408. Claims must detail the date and location of purchase, THE NATURE OF THE PROBLEM, and the name, address and telephone number of the person making the claim. COBB CUSTOM reserves the right and must be given at least a thirty (30) day opportunity to have any product which is the subject of a warranty claim field inspected by a COBB CUSTOM representative.

THIS LIMITED WARRANTY EXTENDS ONLY TO THE ORIGINAL PURCHASER OF PRODUCTS OR TO THE ORIGINAL PURCHASER OF THE STRUCTURE INTO WHICH SUCH PRODUCTS ARE INSTALLED.

COBB CUSTOM makes no other warranty with respect to its products except as set forth above. No distributor, dealer or representative has the authority to change or modify this Limited Warranty. In no instance shall COBB CUSTOM be responsible for indirect, consequential or incidental damage.

This limited warranty gives you specific legal rights, and you may have additional rights, which vary from state to state. Some states do not allow the exclusions or limitations of incidental or consequential damages, so the limitations or exclusions may not apply to you. IN SUCH CASE, THE DURATION OF ANY IMPLIED WARRANTY SHALL BE THE SAME AS THAT OF THIS LIMITED WARRANTY STATED HEREIN.

This Limited Warranty applies to all COBB CUSTOM products.

ADDITIONAL LIMITATIONS AND EXCLUSIONS

THE FOLLOWING SHALL NOT BE CONSIDERED DEFECTS IN MATERIAL OR WORKMANSHIP AND ARE NOT COVERED BY THIS LIMITED WARRANTY:

1. **Outswing doors.**
2. **Any stain (light or dark) and/or clear finishes, or dark colored paint on any COBB CUSTOM product will void warranty.**
 - a. Light colored paints (preferably white) must be used, as light colored paints reflect sunlight, thus deterring the absorption of heat into wood. Dark paints and finishes allow the absorption of heat into the wood, thus accelerating the breakdown of the paint/finish and the possibility of damage to products.
3. Doors with wood panels more than 12" wide.
4. A door which has been trimmed to expose the dowel joint. Cutting into the dowel joint voids this limited warranty. Standard COBB CUSTOM dowel doors are constructed to allow a maximum of one (1) inch to be trimmed from the bottom and one (1) inch to be trimmed from the top without exposing the dowel and voiding the warranty.
5. Failure to remove weatherstripping **prior** to painting/finishing will void warranty.
6. **Finishing is EXTREMELY important on raw and pre-primed wood products (see *Suggestions for Care & Finishing of Wood Windows & Doors*, pages 3 & 4).** Products which have not been sealed on all six sides (top, bottom, two faces and two edges) with three (3) applications of exterior grade paint AFTER trimming and hanging. Door surfaces covered by stain alone shall NOT be considered sealed. Clear finishes are not recommended for exterior use as they weather rapidly and provide poor wood protection.
7. Products that are glazed with glass and do not have both primer and finish coat paint lapping on to the glass at least 1/16". The finish should flow from the wood onto the glass 1/16" to provide assurance against water leakage and protect the glazing putty from drying out. See *Suggestions for Care & Finishing of Wood Windows & Doors*, pages 3 & 4.

LIMITED WARRANTY

8. Products, both pre-primed and raw wood, which have not been sealed to above specifications within ten (10) days of delivery to distributor. Prior to sealing, products must be stored in a dry environment.
9. Warp shall not be considered a defect unless it exceeds 1/4".
10. Warp for any door that is 1 3/8" thick and is wider than 36" or taller than 84".
11. Warp for any door that is 1 3/4" thick and wider than 42" or taller than 96".
12. Improperly installed products.
13. Bow or nonalignment in the frame or jamb in which the door is hung, if such is purchased from COBB CUSTOM unmachined and not prehung.
14. Any 1 3/8" door used as an exterior door.
15. External glass scratches. Must be reported upon receipt to distributor, BEFORE INSTALLATION.

16. Damage caused by others or by circumstances beyond the control of COBB CUSTOM including but not limited to damage caused by misuse, abuse, accident, or mishandling, or by fire, flood, earthquake, storm, tornado or other random acts of nature.

For the purpose of this limited warranty, misuse is defined as, but not limited to, installing a product on any side of a structure without adequate protective overhang. "Adequate overhang" depends on the direction the product faces and therefore its' potential exposure to sunlight and rain:

For NORTH, EAST AND NORTHEAST-FACING PRODUCTS adequate overhang is defined as an overhang projecting a distance one half of the measurement from the bottom of the door to the base of the overhang structure. See Example A below.

For SOUTH, WEST AND SOUTHWEST-FACING PRODUCTS adequate overhang is defined as an overhang projecting a distance equal to the measurement from the bottom of the door to the base of the overhang structure. See Example B below.

In addition to the correct overhang projection above, the overhang must extend out to each side of the door a minimum distance of one foot. These requirements must be met to qualify for warranty coverage.

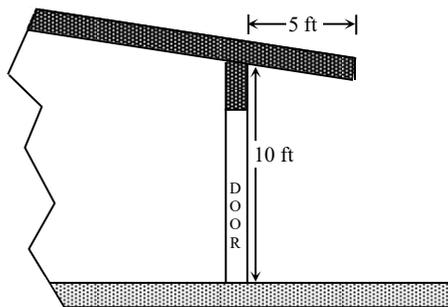

Example A

Adequate Overhang for North, East and Northeast Exposures

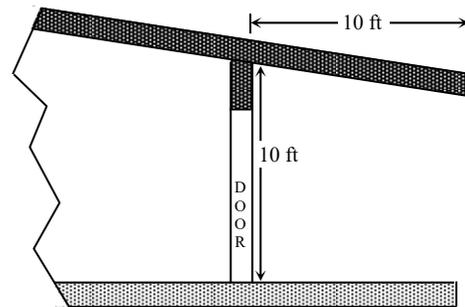

Example B

Adequate Overhang for South, West and Southwest Exposures

17. Failure to perform normal homeowner maintenance as described in COBB CUSTOM *Suggestions for Care & Finishing of Wood Windows & Doors*.
18. Attempts by persons other than authorized COBB CUSTOM representatives to repair COBB CUSTOM products.
19. Surface checks which are less than 1/32" wide and/or 2" tall. Panel movement (shrinkage) of 1/8" or less. Temperature and humidity may cause wood panels in your door to shrink, leaving an unfinished line along the panel edge.
20. Natural variations in wood color and texture.
21. If the claimed nonconformity is warp, COBB CUSTOM may defer repairing or replacing the product for a period of up to twelve (12) months from the date of claim or the date when the product was installed, as it is not uncommon for a temporary warp condition to occur as doors adjust to local humidity and temperature conditions. This deferral will not be counted against this limited warranty period.

SUGGESTIONS FOR CARE & FINISHING OF WOOD WINDOWS & DOORS

- **Stile & Rail Doors**
- **Flush Doors**
- **Solid Wood Windows**
- **Custom Millwork**

The following suggestions are designed to give the users of our products assistance in gaining maximum satisfaction and product life. **Over 90% of all product problems are caused by improper or inadequate painting or finishing. It is strongly suggested that these suggestions be followed or warranty is voided.**

**** Exterior wood doors and windows are only as good as their finish****

FOLLOW CURRENT AAMA (AMERICAN ARCHITECTURAL MANUFACTURERS ASSOCIATION) GUIDELINES WHEN IT COMES TO FLASHING, INSTALLATION AND FINISHING OF ALL COBB CUSTOM WOOD PRODUCTS.

RECEIVING YOUR ORDER:

- Immediately inspect for correctness and damage or defect. Notify your supplier at once of any problem.
- Failure to give immediate notice of error or defect negates later claims.

HANDLING:

- Avoid skidding or sliding on floor as this can split or chip the bottom edges and corners
- Avoid leaning on steep angle as this causes damage to bottom edges.
- Do not drag one product over another as this can cause gouging and scarring damage.
- Large size or heavy windows should not be handled by one person. Racking and twisting will damage the product.

* **Great care must be used in loading and hauling doors and windows. Be sure proper cover doors or panels are used. Watch for sharp or rough projections on truck bodies. Take care in tying to avoid excessive or uneven pressure or rope damage.**

STORAGE:

- Store in a clean, dry room.
- Abnormal humidity, dampness, heat, dryness or rapid changes in same must be avoided.
- **All faces, edges, ends of all products must be primed and painted/finish coat within 10 days from delivery.**
- Doors should be stacked flat on a level surface with stickers top, middle, and bottom of pile.
- Windows may be leaned against a flat, dry surface in a nearly vertical position. Take care to avoid twist or excessive pressure on product.

FITTING:

- * Examine for correctness and quality prior to cutting the product.
- * Excessive cutting for fitting or the application of hardware will impair product strength and usefulness and limit claims for defective service.
- Operating doors and windows should be fitted with adequate clearance. Remember to allow for damp weather swelling.

- We strive to achieve a consistent 1/8"-3/16" reveal/gap vertically and top horizontally for your operating windows and doors.
- Use care in planning to avoid chipping. Select fine tooth saw. All sharp edges should be eased with sandpaper to avoid chipping or splintering.
- Exterior book doors up to 7 ft. high use 3 hinges. Use 4 hinges over 7 ft. high.
- Interior doors require 3 hinges except for hollow core doors weighing less than 50 lbs. or 6'8" or less in height. Doors over 7'6" high require 4 hinges
- **EXTERIOR DOORS MUST HAVE A PROJECTING OVERHANG FOR WEATHER PROTECTION. See Cobb Custom Limited Warranty for proper specifications regarding overhangs and finishing (exclusions #2, 5, 6, 15 and 16).**

FINISHING

- * All weatherstripping must be removed, then replaced only **after** proper finishing, as detailed below.

PAINT GRADE & PRE-PRIMED FLUSH DOORS

- Ease all edges with sandpaper.
- Fill and sand any dings, gouges or blemishes.
- Finish all faces and edges of the door.
- **On pre-primed units, first test in an inconspicuous area for compatibility of top coat and pre-primer. T.M. Cobb cannot guarantee compatibility.**
- Apply 3 coats high-grade exterior primer according to paint manufacturer's instructions. Lacquer-based primer or sealers should not be used.
- Apply 3 coats high-grade exterior finish paint compatible to primer used and in accordance with paint manufacturer's instructions.
- All exterior doors must be finished with approved good grade exterior finish in accordance with manufacturer's instructions.
- Dark exterior colors should be avoided where long exposure to hot sun is expected.
- **Note: All six surfaces must be fully painted – 2 faces, 2 edges, top and bottom.**
- Final sand with 3/0 and 5/0 sandpaper, taking care to remove marks, bruises and imperfections.
- For a superior job, apply a paste wood filler according to manufacturer's directions.

STAIN FINISH FLUSH DOORS

- After stain and sealer has been applied, the door must be finished with a minimum of 2 coats of good grade varnish or equivalent product in accordance with manufacturer's directions.
- Proper sanding between coats enhances quality of the finish job.
- Exterior designed finishes must be used on all exterior doors including top, bottom and edges.
- Immediately after fitting, cutting for weatherstripping and hardware, all raw wood must be primed and finished with 2 coats of finish as described above.
- **Note: All six surfaces must be fully painted – 2 faces, 2 edges, top and bottom.**

STILE AND RAIL DOORS:

- **Check panel alignment – one or two panels may need realignment. Tap into place using soft wood block and hammer. Back bed any stop-glazed lites with putty. See Detail B, below.**
- Sand out or fill and sand any blemishes. Sand with the grain. Ease any sharp edges caused by fitting.
- Finish sand with 5/0 sandpaper and clean and dust thoroughly.
- For Paint Finish:
 - **On pre-primed units, first test in an inconspicuous area for compatibility of top coat and pre-primer. TM Cobb cannot guarantee compatibility.**
 - Apply 3 coats high-grade exterior primer according to paint manufacturer's instructions. Lacquer-based primer or sealers should not be used.
 - Apply a minimum of 3 coats of high-grade exterior finish paint compatible to primer used and in accordance with paint manufacturer's instructions.
 - **Note: All six surfaces must be fully painted – 2 faces, 2 edges, top and bottom**

WARNING! WARNING! WARNING! WARNING!

- The use of stains and/or clear finishes, or dark finishes of any kind on the exterior of the product **VOIDS your Cobb Custom Limited Warranty (see exclusions #2 and 16).**
- Stains and/or clear finishes, or dark finishes of any kind weather rapidly resulting in poor wood protection.
- Stains and clear wood finishes require recoating as often as once a year. Use at your own risk as you will **VOID your Cobb Custom Limited Warranty.**

DOORS, WINDOWS OR SASH GLAZED WITH STOPS

Inspect around each lite of glass to assure that a solid line of putty exists. Where voids exist, back putty with putty knife using good grade of putty. Be sure to cover putty by lapping paint onto glass to insure a weathertight seal.

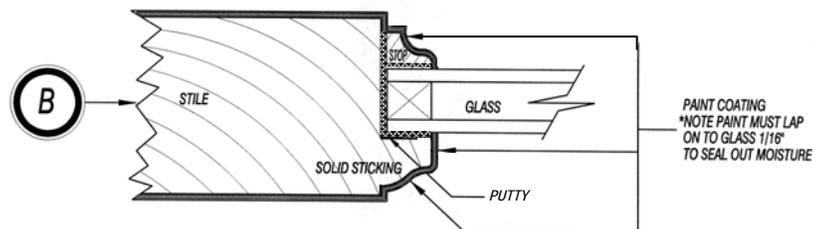

GLAZED DOORS: Government Regulations dictate the use of Tempered Glass or Laminated Glass. Such glass has etched labels (bugs) and tong marks near the edge of each lite as a standard. Prior to painting, we recommend masking each lite to protect from painting or cleaning damage.

THANK YOU!

Our employees and owners wish to thank you for selecting one of our many quality products. We sincerely hope you are pleased with your selection and that you will specify a **Cobb Custom** product the next time you have need.

STILE AND RAIL DOORS cont'd...

- **ALL COBB CUSTOM PRODUCTS MUST BE FINISHED WITHIN 10 DAYS OF DELIVERY TO DISTRIBUTOR OR COBB CUSTOM WARRANTY WILL BE VOID.**

WOOD WINDOWS AND SASH:

- Touch up putty work as required.
- Fill and sand any dings, gouges or voids.
- Sand all faces and bar work with care given to avoid scratching glass.
- Dust and wipe clean.
- Prime all wood and putty surfaces lapping paint onto glass for weather seal. **Priming must be completed prior to any exposure to the weather.**

LAP PAINT ON TO GLASS 1/16" FOR WEATHER

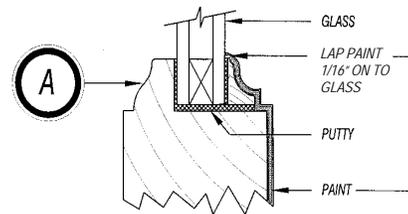

- **On pre-primed units, first test in an inconspicuous area for compatibility of top coat and pre-primer. TM Cobb cannot guarantee compatibility.**
- 3 coats high-grade exterior primer should be used in accordance with the paint manufacturer's instructions. Lacquer-based primer or sealers should not be used.
- Apply a minimum of 3 coats of high-grade exterior finish paint compatible to primer used and in accordance with paint manufacturer's instructions.
- Be certain that window cleaners do not cut into the area where paint laps onto glass beyond 1/16 inch above putty. **THE PAINT IS THE SEAL** and must protect all wood and putty from moisture.
- The use of stains and/or clear finishes, or dark finishes of any kind on the exterior of the product **VOIDS your Cobb Custom Limited Warranty (see exclusions #2 and 16).** Stains have proven ineffective in protecting wood windows and sash.
- If double hung windows stick from paint, do not lift on center of check rail as it may separate from glass causing product damage.
- **ALL COBB CUSTOM PRODUCTS MUST BE FINISHED WITHIN 10 DAYS OF DELIVERY TO DISTRIBUTOR OR COBB CUSTOM LIMITED WARRANTY WILL BE VOID.**